

RULLO ESTENSORE CURVO

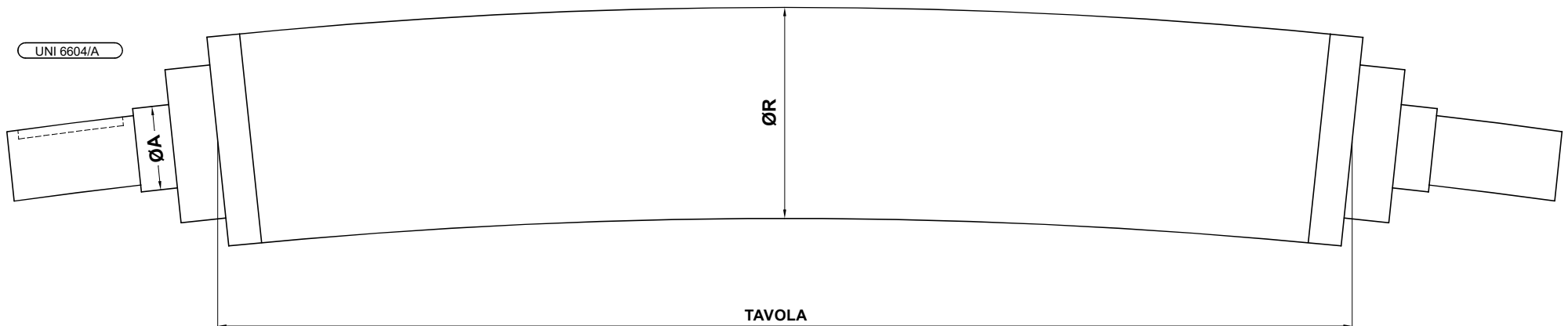

MODELLO	Ø RULLO R	DIMENSIONI TAVOLA		Ø PERNO A	TIPO DI SUPPORTO
		MIN	MAX		
EGN 075	75	500	1600	30	SG1-SP1
EGN 085	85	500	2000	35	SG1-SP1
EGN 100	100	1400	2500	40	SG2-SP2
EGN 125	125	1400	3400	45	SG2-SP2

ESECUZIONE SPECIALE CON PULEGGIA TRAPEZOIDALE

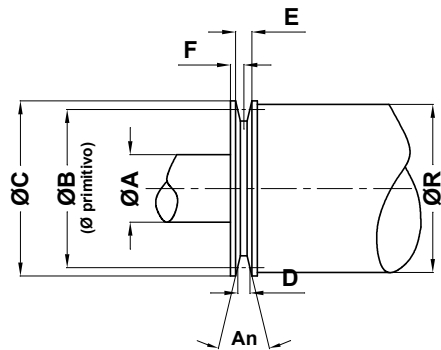

MODELLO	Ø RULLO R	DIMENSIONI							SEZIONE CINGIA
		A	B	C	D	E	F	An	
EGN 075	75	30	75	79.6	8.5	9.7	8	34°	SPZ
EGN 085	85	35	85	89.6	8.5	9.7	8	38°	SPZ
EGN 100	100	40	100	104.6	8.5	9.7	8	38°	SPZ
EGN 125	125	45	125	129.6	8.5	9.7	8	38°	SPZ



SUPPORTO A FLANGIA

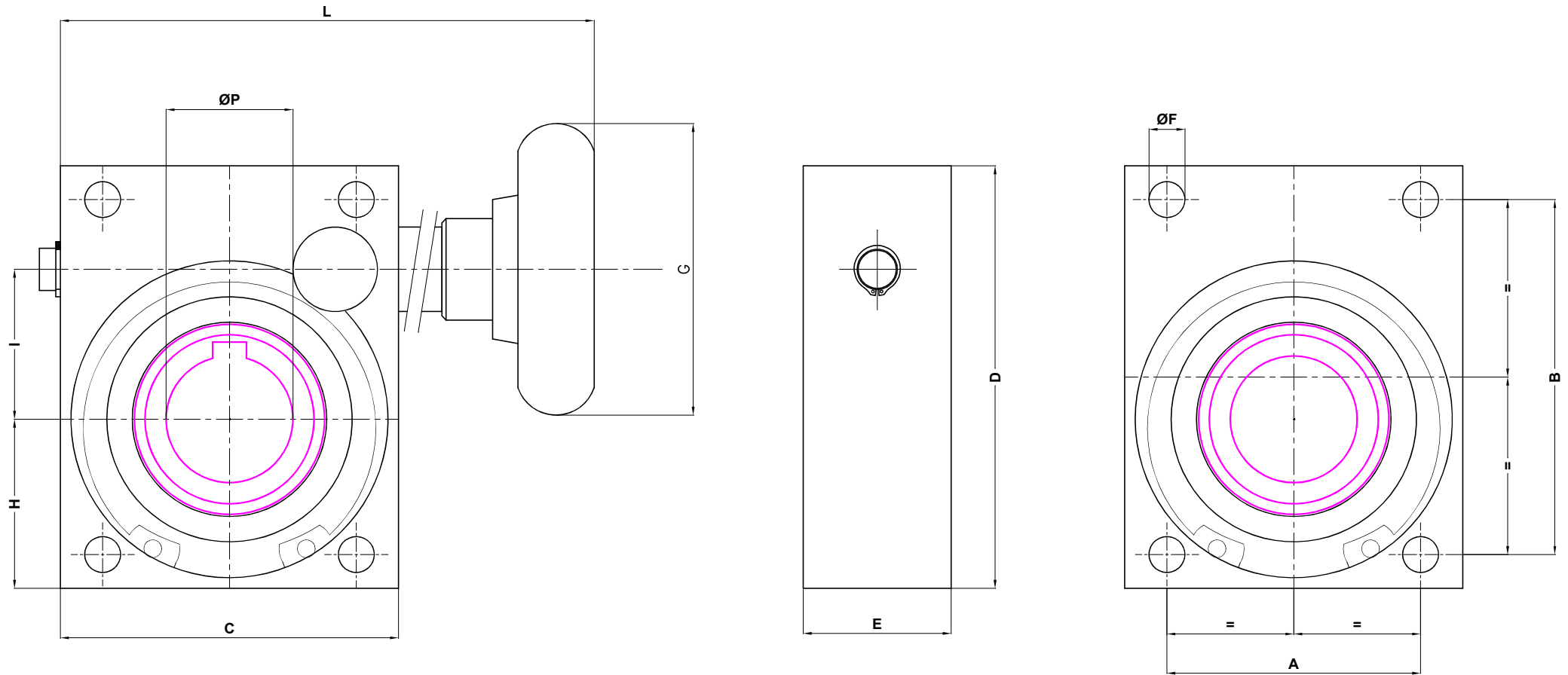

MODELLO	TIPO DI RULLO	DIMENSIONI										
		A	B	C	D	E	F	G	H	I	L	P
SG1	EGN 075-085	60	84	80	100	35	8.5	69	40	35.5	170	25-30
SG2	EGN 100-125	100	120	120	140	50	10.5	82	69	41	245	35-40



SUPPORTO A PIEDE

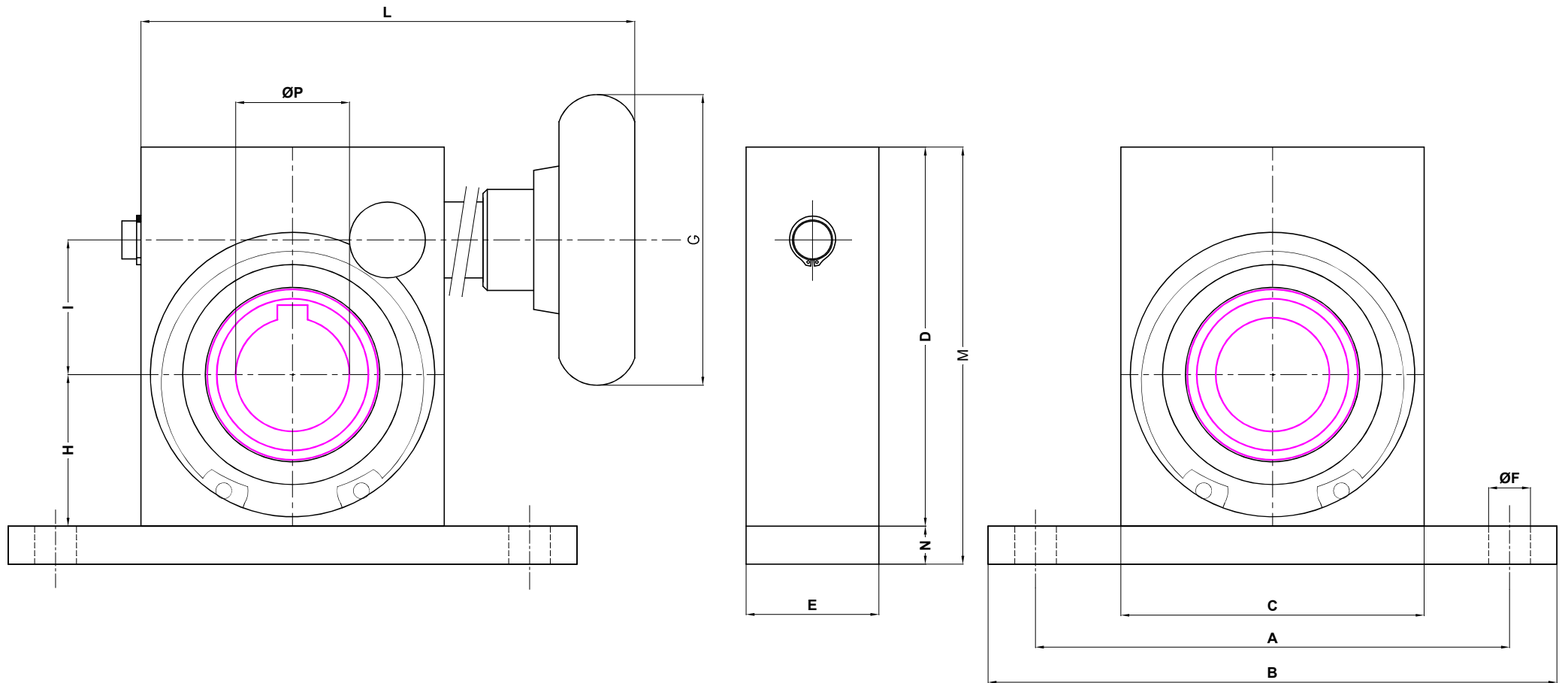

MODELLO	TIPO DI RULLO	DIMENSIONI												
		A	B	C	D	E	F	G	H	I	L	M	N	P
SP1	EGN 075-085	125	150	80	100	35	11	69	40	35.5	170	115	15	25-30
SP2	EGN 100-125	160	200	120	140	50	13	82	69	41	245	160	20	35-40

